

03A	ROHS UPDATE	M. HALL	S. FOSTER	M. HALL	ANURA	31JUL06
02A	CIRCUIT ADJUSTMENTS	ADAM. D	S. FOSTER	M. HALL	ANURA	18JAN05
01A	SECOND PROTOTYPE	M. HALL	S. FOSTER	M. HALL	ANURA	24NOV05
00A	DESIGN PROTOTYPE	S. FOSTER	M. HALL	M. HALL	ANURA	13JUL04
REV/ISS	AMENDMENTS	DRAWN	CHKD	D. O.	APVD	DATE

© TAIT ELECTRONICS A2  
 TA2444-01  
 TB8000 CHANGE-OVER  
 IPN: 228-24441-03 ISSUE: A VARIANT NUMBER: ?  
 FILE DATE: Mon Jul 31 09:22:58 2006  
 ENGINEER: Shawn Foster FILE NAME: 22B\_24441 SHEET NUMBER: 1 OF 3

# BOARD A

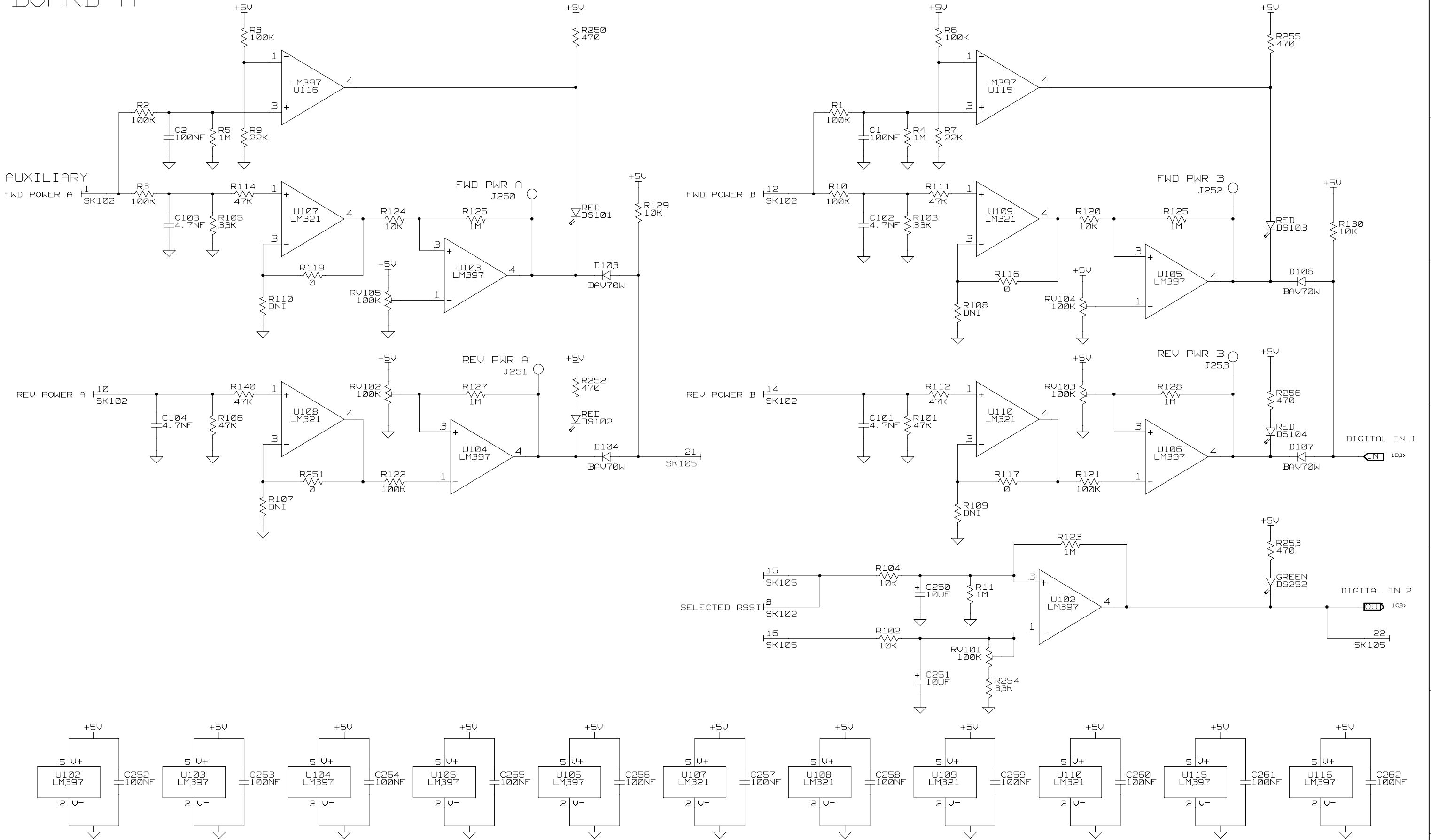

03A	ROHS UPDATE	M. HALL	S. FOSTER	M. HALL	ANURA	31JUL06
02A	CIRCUIT ADJUSTMENTS	ADAM. D	S. FOSTER	M. HALL	ANURA	18JAN05
01A	SECOND PROTOTYPE	M. HALL	S. FOSTER	M. HALL	ANURA	24NOV05
00A	DESIGN PROTOTYPE	S. FOSTER	M. HALL	M. HALL	ANURA	13JUL04
REV/ISS	AMENDMENTS	DRAWN	CHKD	D. O.	APVD	DATE

© TAIT ELECTRONICS A2  
 TA2444-01  
 TB8000 CHANGE-OVER  
 IPN: 228-24441-03 ISSUE: A VARIANT NUMBER: ?  
 FILE DATE: Mon Jul 31 09:24:51 2006  
 ENGINEER: Shawn Foster FILE NAME: 228-24441 SHEET NUMBER: 2 OF 3

LOCAL

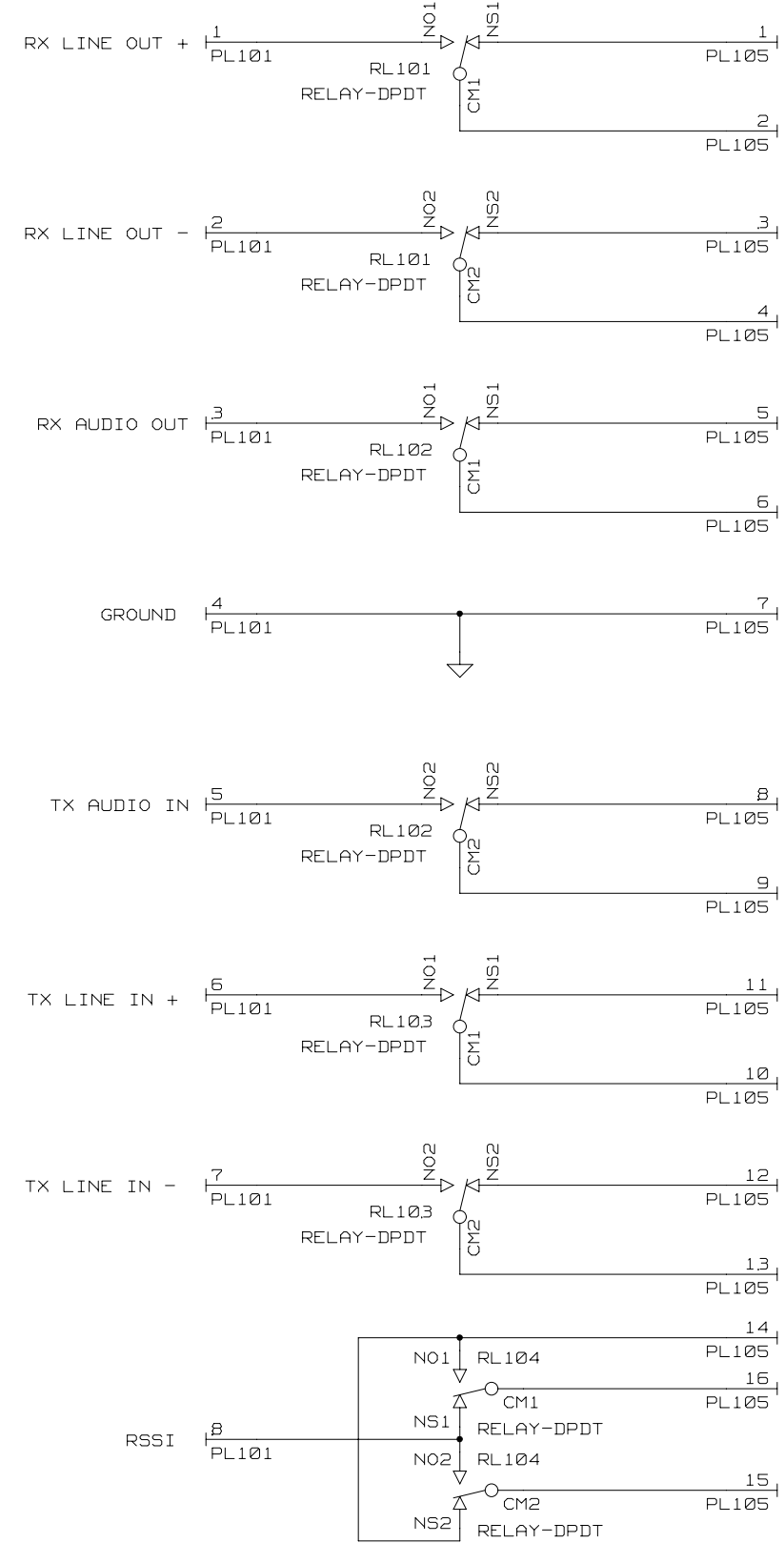

BOARD B

LOCAL

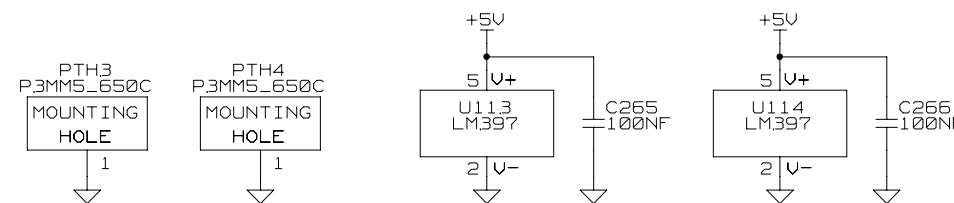
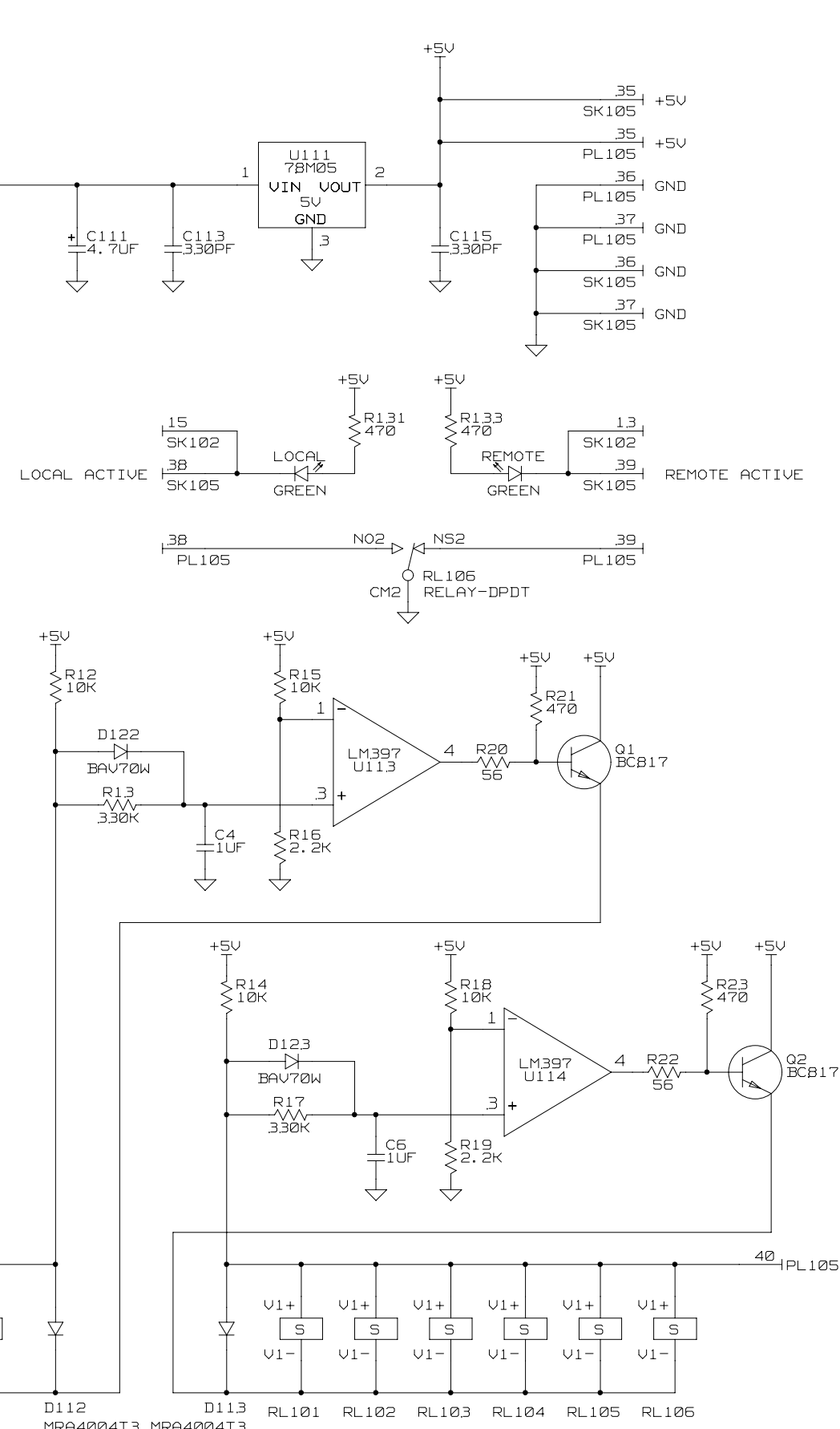
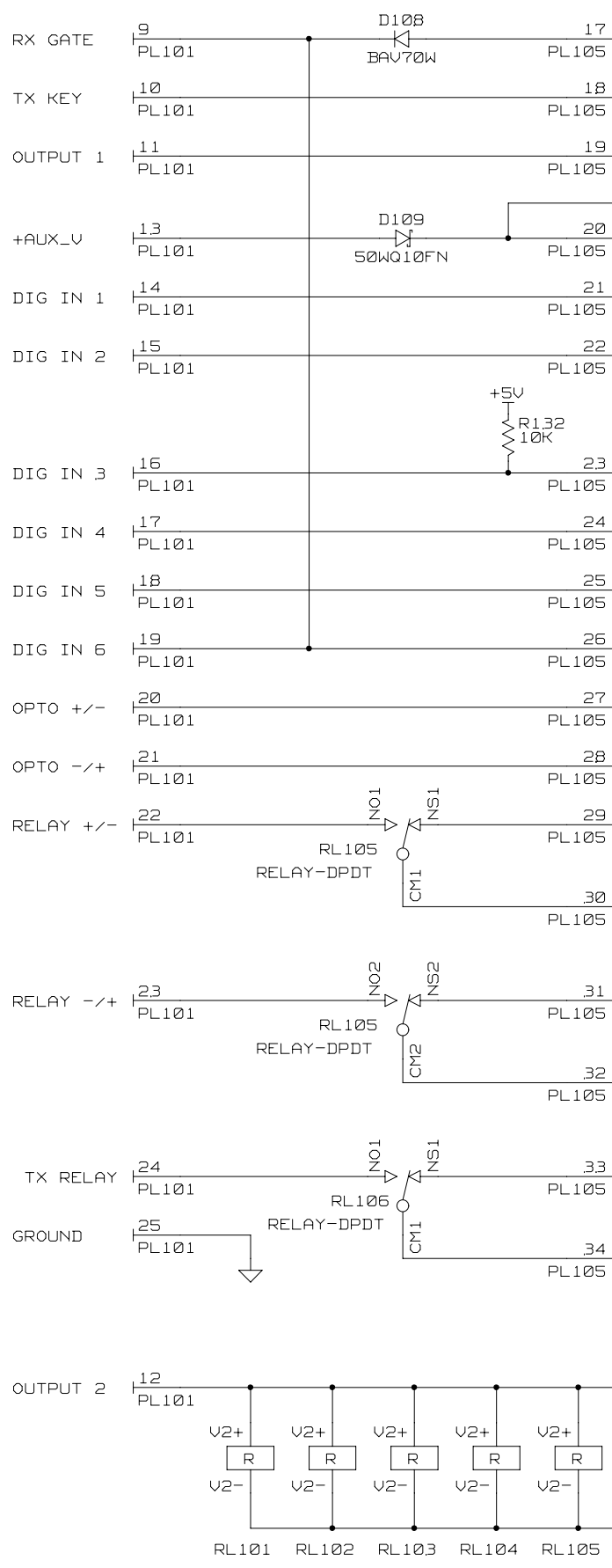

03A	ROHS UPDATE	M. HALL	S. FOSTER	M. HALL	ANURA	31JUL06
02A	CIRCUIT ADJUSTMENTS	ADAM. D	S. FOSTER	M. HALL	ANURA	18JAN05
01A	SECOND PROTOTYPE	M. HALL	S. FOSTER	M. HALL	ANURA	24NOV05
00A	DESIGN PROTOTYPE	S. FOSTER	M. HALL	M. HALL	ANURA	13JUL04
REV/ISS	AMENDMENTS	DRAWN	CHKD	D. O.	APVD	DATE

© TAIT ELECTRONICS A2  
 TA2444-01  
 TB8000 CHANGE-OVER  
 IPN: 228-24441-03 ISSUE: A VARIANT NUMBER: ?  
 FILE DATE: Mon Jul 31 09:24:44 2006  
 ENGINEER: Shawn Foster FILE NAME: 22B-24441 SHEET NUMBER: 3 OF 3